

CONNECTING THE SLS TO PROTECT SPEAKERS

1. The SLS-HW should be connected directly before the speaker you wish to protect. The SLS-HW is not weatherproof: if the speaker is outdoors, it will need to be covered and protected from the elements. Ground the SLS by connecting one of the center screw GND terminals of the SLS to a good earth ground.
2. Connect the speaker to the EQUIPMENT terminals of the SLS-HW.
3. Connect the speaker line to the LINE terminals of the SLS-HW.

Typical hook-up example to protect speakers:

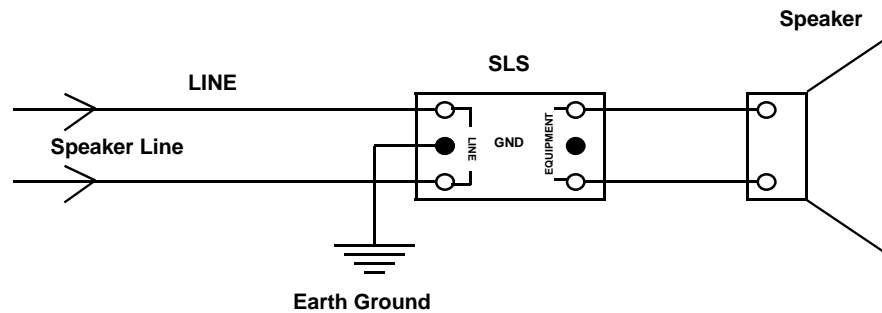

NOTE:

The SLS is uniquely designed to prevent induced lightning surges that can occur to speaker lines from damaging the connected equipment. It is not intended to replace any other surge protectors. For the protection of all other lines entering and leaving your equipment, consult a professional who specializes in surge protection.



**Grommes~Precision
Precision Electronics**



SLS-HW Speaker Line—Lightning Suppressor



Grommes~Precision

847-599-1799 800-SINCE-46 FAX: 847-599-6178
1331 Estes Ave. Gurnee, IL 60031 USA

www.grommesprecision.com

SLS-HW INSTRUCTIONS

Description

The SLS-HW is uniquely designed to prevent induced lightning surges that can occur to speaker lines from damaging the connected equipment. Simply locate the SLS-HW within the speaker line right after the amplifier to protect that amplifier, or directly before the speaker to protect that speaker.

Features

- Induced lightning strike protection
- Triple protection—primary and secondary series and shunt.

Specifications

Maximum Voltage: 200V RMS balance
Clamping Voltage: Approximately 350V

Maximum Permissible Loads:

100V:	2000W
70V:	1400W
25V:	500W
8 OHM:	1600W
4 OHM:	1250W

UNPACKING PROCEDURES

Inspect the shipping container and unit for indication of improper handling. This unit was carefully checked and packed before leaving the factory. If the unit has been damaged, make an immediate claim to the dealer or distributor from whom it was purchased. If the unit was shipped to you, notify the transportation company without delay, saving all packing materials, in order to process the claim. 800-SINCE-46

CONNECTING THE SLS TO PROTECT THE ELECTRONIC EQUIPMENT

Verification of Powered Equipment's Earth Ground

Verify that the electronic equipment that you wish to protect (i.e. the amplifier) is connected to a good earth ground. If the AC receptacle is grounded, then equipment with a 3-prong line cord will also be grounded. If the amplifier to be protected uses only a 2-conductor AC line cord, then a separate ground wire should be connected from earth ground to the amplifier chassis. To ensure the integrity of the earth ground, consult a licensed electrician.

Connecting the SLS-HW

1. The SLS should be located close to the electronic equipment you wish to protect on the speaker line. Ground the SLS by connecting one of the center screw GND terminals of the SLS to a good earth ground.
2. Connect the equipment's output to the EQUIPMENT terminals of the SLS.
3. Connect the load to the LINE terminals of the SLS.

Typical hook-up example to protect electronic equipment:

